

FEATURES

- Features patent-pending “high tech” packings:
 - dynamic low-pressure seal retainer
 - superior low-pressure seal
 - innovative intermediate ring
 - superior high-pressure seal
- Ceramic plungers
- Patent-pending inlet/outlet valve cage
- Nickel-plated forged brass manifold with an exclusive lifetime warranty
- Heavy-duty tapered roller bearings
- Specifically designed to handle rigorous duty cycles, high temperatures and chemicals
- Ideal for use in car wash and other high pressure cleaning applications



Emperor
Pumps That Rule Any Environment

**SPECIFICATIONS**

Pump Model	HTCK4050S
Maximum Volume	36.0
Maximum Pressure	1500
Maximum RPM	800
Maximum Inlet Pressure	125 PSI
Minimum Inlet Pressure	3 ft. water (2.6 in. Hg)
Maximum Fluid Temperature	185°F
Bore (in / mm)	1.6 in./40 mm
Stroke (in / mm)	1.9 in./50 mm
Oil Capacity	124.4 oz.
Inlet Port Thread	1-1/2"-11 BSP-F
Discharge Port Thread	1"-11 BSP-F
Shaft Diameter	1.9 in./40 mm
Weight	157 lbs.
Dimensions - Nominal	20.7" x 14.5" x 9.9"

Instructions and Recommendations for the Installation of *HT Series Pumps*

The high-temperature pumps of the HT series have been designed for use in applications where the water must be pre-heated, such as in carwash, food and pharmaceutical industries.

Maximum temperature of the water through the pump is 185°F (85°C).

In order to obtain maximum performance in terms of duration of seals and valves, it is necessary to respect a few simple rules, as follows:

1) **In order to avoid damage caused by cavitation, the pump must be pressure fed.**

The higher the inlet pressure, the longer the life of the wet end of the pump.

When working at 185°F (85°C), the minimum feed pressure - measured directly in the inlet port of the pump when it is working - is 45 psi (3 bar).

The minimum feed pressure according to the different temperatures are:

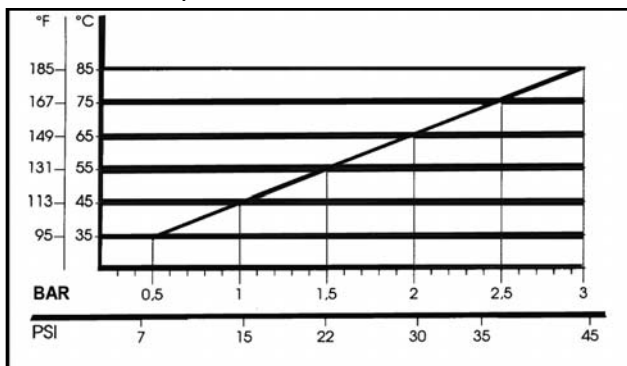

Naturally, if the application allows for feeding the pump with 45 psi (3 bar) even at low temperatures (for example: 115°F/45°C the life of the wet end of the pump will be even longer.

2) **The plumbing which feeds the pump must be of a diameter at least equal to the inlet port.**

Also, follow the suggestions below:

a) Make the plumbing as short and straight as possible, preferably in an upward direction to facilitate the expulsion of eventual air bubbles naturally if compatible with the requirements of the system.

b) It is always useful to put a filter at the inlet with capacity of 4 to 5 times the flow of

the pump, for example for a 4 gpm (15 l/min) pump, put a filter from 16 to 20 gpm (60-75 l/min). The mesh size suitable for this application is 0.016" (.4 mm).

c) It is extremely important to put a pressure switch on the suction port of the pump, and in any case downstream from the filter, so that it can stop the pump should the feed pressure drop by 20% due to the filter clogging or failure of the feed pump, etc.

3) **Change of oil**

We recommend the **first oil change after the first 50 hours**, with the **pump stopped** and the **oil still warm**.

This change is not recommended because the oil has lost its properties, but rather to eliminate the impurities that have gotten into the oil during the running-in phase. If these impurities are not removed, but are allowed to remain in the oil, they may cause premature wear to the moving parts and the oil seals. **After this initial change, the oil can then be changed every three months or 300 hours of operation thereafter.**

Please note: If the pump works in conditions with high humidity and with sharp temperature changes, it is possible that condensation will appear inside the crankcase, which mixing with the oil can change its properties. This is easy to see because the oil changes to a white, milky color.

If the pump does not have excessive water leaking from the packings, and the oil becomes milky, the oil has to be changed more frequently. The percentage of water in the oil must not exceed 20%.

Use oil per the following chart:

CHART OF COMPATIBLE OILS SAE15W40	
GENERAL PUMP	SERIES 100
BP	VISCO 2000
CASTROL	CWX
MOBIL	SUPER
SHELL	HELIX SUPER
TOTAL	QUARTZ 4000-5000

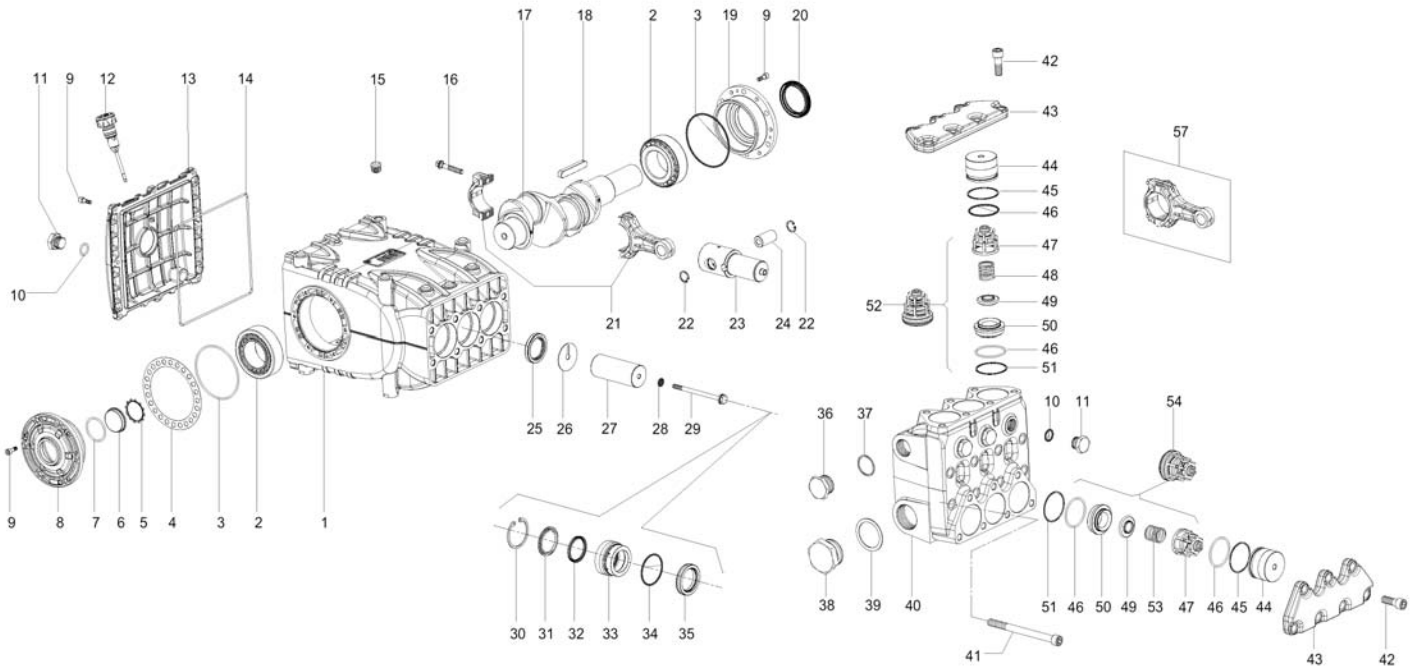

PARTS LIST

ITEM	PART NO.	DESCRIPTION	QTY	ITEM	PART NO.	DESCRIPTION	QTY	ITEM	PART NO.	DESCRIPTION	QTY
1.	71010022	Crankcase	1	18.	91500000	Key	1	40.	71123241	Manifold, Nickel-plated, 40 mm, G	1
2.	91859000	Bearing, Tapered Roller	2	19.	71150022	Crankcase Cover, Open	1	41.	71123341	Manifold, Nickel-plated, 40 mm, NPT	1
3.	90391800	O-ring	2	20.	90170000	Crankshaft Oil Seal	1	42.	99448000	Screw, M12 x 150	8
4.	71220081	Shim	1	21.	71030043	Connecting Rod	3	43.	99429500	Screw, M12 x 35	14
	71220381	Shim	1	22.	90060600	Circlip	6	44.	71210136	Valve Cover	2
5.	90075600	Retainer	1	23.	71050015	Plunger Guide	3	45.	71211170	Plug	6
6.	70211801	Oil Level Indicator	1	24.	97743000	Wrist Pin	3	46.	90525000	Anti-extrusion Ring	6
7.	90387700	O-ring	1	25.	90167800	Plunger Rod Oil Seal	3	47.	90388900	O-ring	12
8.	71150122	Side Cover, Sight Glass	1	26.	96714000	Flinger Washer	3	48.	36204551	Valve Guide	6
9.	99186700	Screw, M6 x 18	20	27.	71040509	Plunger, 40 mm	3	49.	94755000	Spring, Outlet	3
10.	90384100	O-ring	4	28.	90367100	O-ring	3	50.	36204456	Valve Poppet	6
11.	98218100	Plug, 1/2"G Nickel-plated	4	29.	71219566	Plunger Bolt	3	51.	36204156	Valve Seat	6
12.	98212000	Oil Dipstick	1	30.	90079700	Circlip	3	52.	90524000	Anti-extrusion Ring	6
13.	71160022	Crankcase Cover, Rear	1	31.	71218970	Spacer	3	53.	36713701	Valve Assy., Outlet	3
14.	90400000	O-ring	1	32.	90245000	L.P. Seal, 40 mm	3	54.	94754000	Spring, Inlet	3
15.	98206000	Rubber Plug	7	33.	71216670	Retainer, Intermediate, 40 mm	3	55.	36713601	Valve Assy., Inlet	3
16.	99313800	Screw	6	34.	90389100	O-ring	3	57.	71030001	Connecting Rod	3
17.	71020035	Crankshaft	1	35.	90246000	H.P Seal, 40 mm	3				
				36.	98232600	Plug, 1" G, Nickel-plated	1				
				37.	93198500	Washer	1				
				38.	98244000	Plug, 1-1/2" G, Nickel-plated	1				
				39.	93199000	Washer	1				
								HT150RCK		Rail Conversion Kit	

REPAIR KITS

KIT NO.	K2012	K2013	K2033	K2034
ITEM NO'S INCLUDED IN KIT	46, 47, 49 50, 51, 53 (54)	46, 47, 48, 49, 50, 51, (52)	32, 35	30, 31, 32, 33, 34, 35
NUMBER OF ASSY'S IN KIT	3	3	3	1
NO. OF CYLINDERS KIT SERVICES	3	3	3	1

TORQUE SPECS*

Position	Ft.-Lbs.	Nm.
9	7.4	10
11	29.5	40
16	28.0	38
29**	14.7	20
36	110.6	150
38	110.6	150
42	88.5	120
56	16.2	22

*Decrease torque by 20% if threads are lubricated.

**Use Loctite 542.

DIMENSIONS

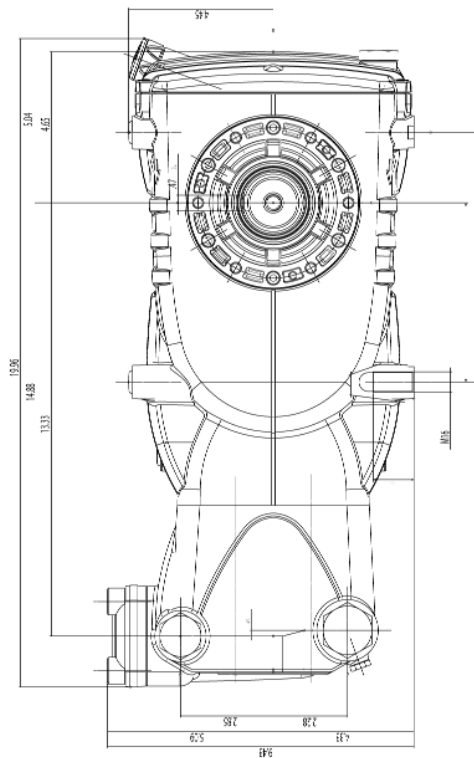
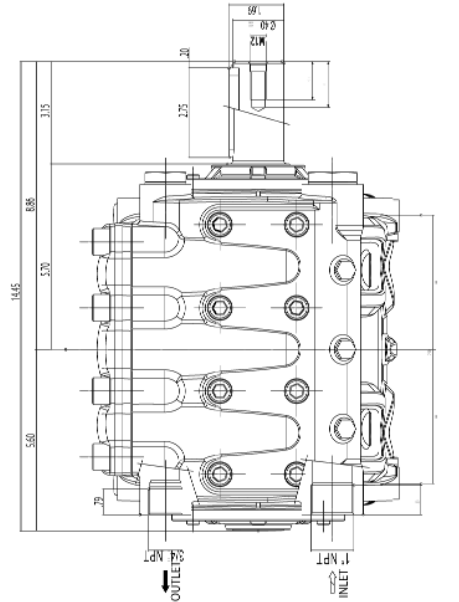

Ref 300607 Rev.B
10-06